

Erosion and Sediment Control

A Guide for Individual Building Sites



Protecting Water Quality

Construction activities without proper erosion and sediment-control protection can contribute large amounts of sediment and other pollutants to creeks, rivers and lakes.

The lack of controls at individual home sites can result in water-quality degradation and may result in compliance violations.

LCRA developed this guide to assist you in preparation of an erosion and sediment control (ESC) plan for your individual building site. It contains a sample plan for a typical single family lot and a worksheet on the back page for you to develop an ESC plan for your site. This plan will help aid in the installation, inspections and maintenance of erosion and sediment control measures.

Regulatory Requirements

LCRA and the Texas Commission on Environmental Quality (TCEQ) have developed regulations that make it illegal to discharge sediment-laden water and other construction-related pollutants to storm sewers or waterways.

LCRA requires the use of erosion and sediment controls for all land-disturbing activities that are not related to agriculture.

LCRA requires written notification for development projects with less than 10,000 square feet of new impervious cover or that will disturb less than one acre. Written notification is also required for the construction of a single-family home or associated structure that adds more than 10,000 square feet of impervious cover (downstream buffer requirements also apply). All development that adds more than 10,000 square feet of impervious cover or disturbs more than one acre land may require a permit through the Highland Lakes Watershed Ordinance. **Contact LCRA's Watershed Management Department (1-800-776-5272, Ext. 2091) for more information on permitting requirements.**

TCEQ requires a stormwater pollution prevention plan (SWP3) for construction projects that disturb more than one acre or is part of a larger common plan, such as a subdivision. For more information please see the following TCEQ Web site: www.tceq.state.tx.us/nav/permits/wq_construction.html or call (512) 239-1000.



This residential management site shows poor management of bare soil areas. No erosion and sediment controls are present, and the grade on the existing slope is inadequate. Temporary or permanent seed, sod or mulch must be applied as soon as final grade is achieved. No slopes steeper than 3:1 are recommended.

You may also need to contact your local county or city officials for any additional permitting requirements.

Erosion and Sediment Controls are Needed

Both erosion and sediment control practices are required on construction sites to prevent excessive sediment from leaving the site.

Erosion Control

Erosion control practices are used to prevent erosion from occurring at construction sites with bare soils. Practices include mulch, compost blankets, temporary and permanent seeding, diversion berms, rolled erosion control products, fencing off sensitive areas, and minimizing land clearing.

Sediment Control

Sediment control practices are used to capture eroded or eroding sediments that are transported by stormwater and keep them on site. These controls are typically placed along the down-gradient perimeter of disturbed areas. Practices include silt fences, rock berms, fiber rolls, stabilized construction entrances, and concrete washout pits.

Common Pollutants at Construction Sites

- Sediment from grading operations, bare soils and sand
- Concrete wash from tools and trucks
- Sanitary waste and pathogens from portable toilets
- Debris from discarded building materials
- Oil and grease from equipment and vehicles
- Paint, chemicals, solvents, and washing of associated equipment
- Litter

Contractor/Builder Responsibilities

1. Install needed erosion and sediment control practices prior to any land disturbance to prevent excessive sediment from leaving the site. (Use **worksheet on the inside back page to help with the ESC plan for your site.**)
2. Contact an LCRA inspector to answer any questions regarding site plan and to review a completed worksheet.
3. Periodic inspection and maintenance are vital to the performance of erosion and sediment controls. It is recommended that all temporary erosion controls be inspected weekly and after every rainfall.
4. Contact an LCRA inspector when construction is complete and the site has been stabilized with permanent vegetation or other approved methods.

Compliance Checklist

- Inlet Protection** — Install ESCs for curb inlets along streets and area inlets. Curb inlets must be completely protected (no gaps) with an opening at top for overflow. Maintenance shall include removal of sediment following each rain event and replacement of failing materials. Do not allow sediment to enter inlet during maintenance. ESCs must remain in place.
 - Perimeter Controls** — Install ESCs along the back of the curb and along the lot line of adjacent properties, which are downhill and receive runoff from your lot. Following sidewalk installation, ESCs should be removed to the back of the sidewalk to prevent sediment from reaching the sidewalk. Maintain ESCs to ensure proper function, including repair or replacement of torn, degraded or otherwise ineffective materials. Remove sediment deposits as necessary to provide adequate protection.
 - Stockpiles** — Install sediment controls around stockpiles to prevent sediment from reaching the street and adjacent properties. Locate stockpiles away from the street, property lines and drainage ways.
 - Lot Access** — Required for each individual lot. Maintain a surface suitable for parking and unloading that prevents the tracking of mud and rock onto the street. A minimum 6-inch depth of 3- to 5-inch aggregate is suggested. All vehicles that access the lot must use the construction entrance. Any soils that are trucked onto the street must be removed by the end of the day.
 - Intermediate Control** — Long or steep drainage paths may require intermediate or interior ESCs to help slow the flow of runoff. Failure of perimeter controls due to the force of runoff often determines the need for intermediate controls.
 - Maintenance** — ESCs should be routinely inspected and maintained until site is permanently vegetated. Sometimes routine inspections may show a need for adjustments or the addition of new ESCs.
 - Dewatering** — Dewatering of trenches, foundations or other excavated areas should be done in such a manner that does not deposit sediment off site or cause erosion. Sediment-laden water must be treated before discharging off site. This may include the use of a sediment basin, silt fencing or vegetated areas. Use a designated concrete washout area to prevent wash water from concrete tools or trucks from entering drainage ways.
 - Revegetate the Site** — Prevent erosion on individual lots with ground cover. Existing trees and vegetation should be protected to help maintain a stable ground surface and prevent loss of valuable topsoil. Erosion control blankets, matting and mulches can help stabilize the area until permanent vegetation is established. The site needs to have at least 70 percent coverage of permanent vegetation before ESCs can be removed.
 - Housekeeping** — Provide adequate sanitary facilities and trash/refuse bins.
- Train and educate construction crews to better understand the effects of stormwater pollution from construction projects and how to prevent and minimize pollution on the job.**

Single Family Lot Erosion and Sediment Control Plan

This diagram illustrates the key points to protecting individual building sites. Every building site is unique and should be evaluated for potential erosion and sediment loss. Rain falling and water flowing over bare ground will create erosion. Understanding the drainage patterns on the site and where stormwater runoff will flow is critical in planning for erosion control. (The use of topographic maps is recommended in showing drainage pattern, areas of concentrated flows, and approximate gradient of slopes. Maps are available from the U.S. Geological Survey at the Web sites store.usgs.gov or tims.lcra.org

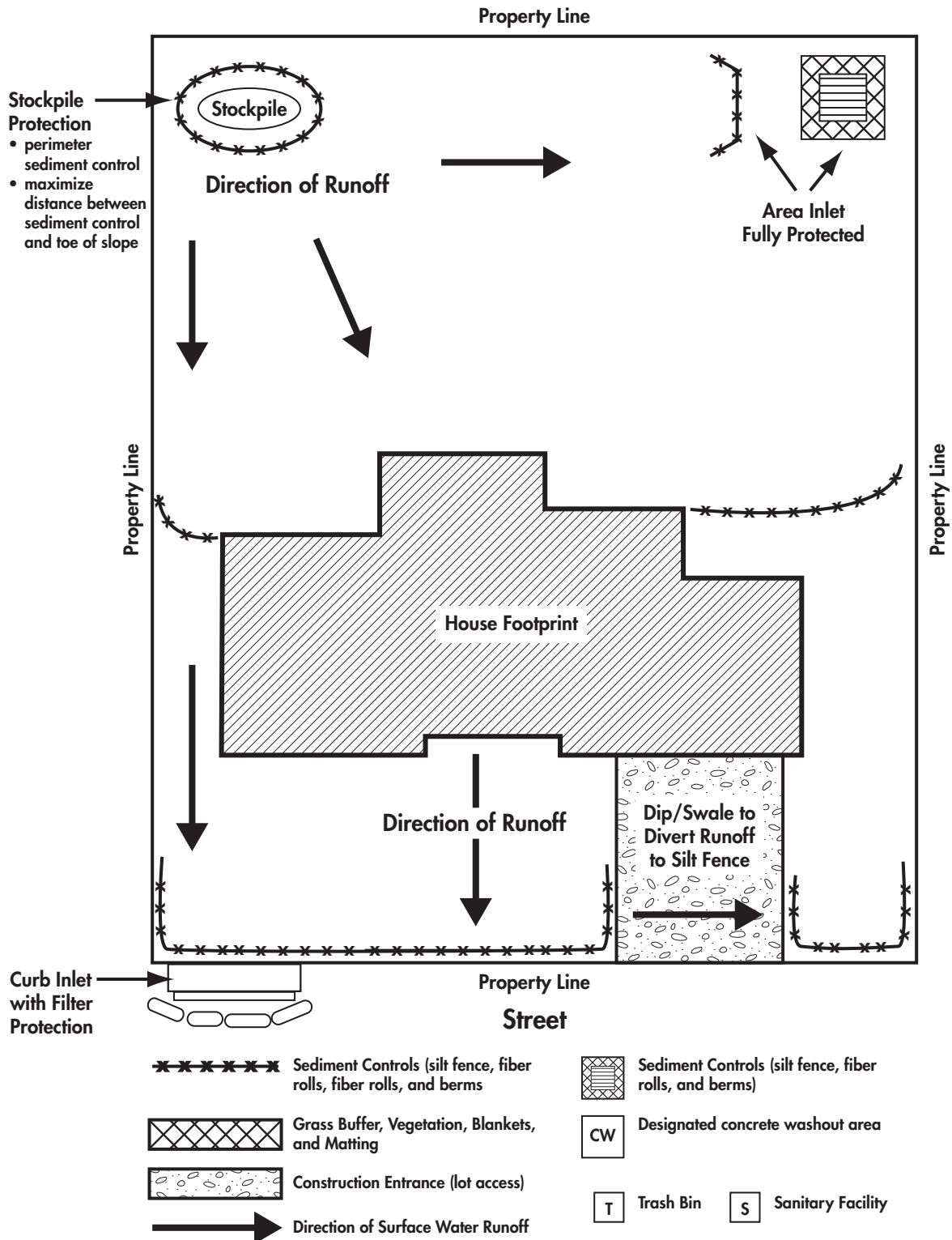

The Effective Use of Erosion and Sediment Control Practices

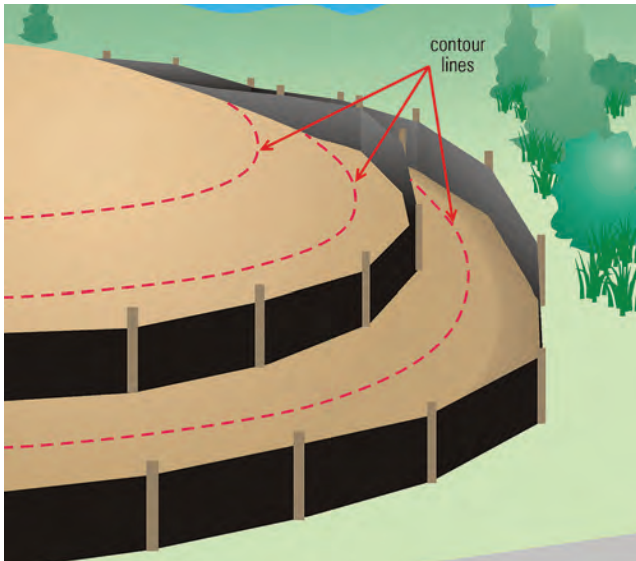

Silt fences should be installed on the contour below bare soil areas. Use multiple fences on long slopes per Technical Manual. Remove accumulated sediment when a depth of 6 inches is reached.



Poor installation of silt fencing, fair to good seeding. Silt fence must be trenched in along bottom and include wire backing. Straw bales are not approved as sediment barriers.

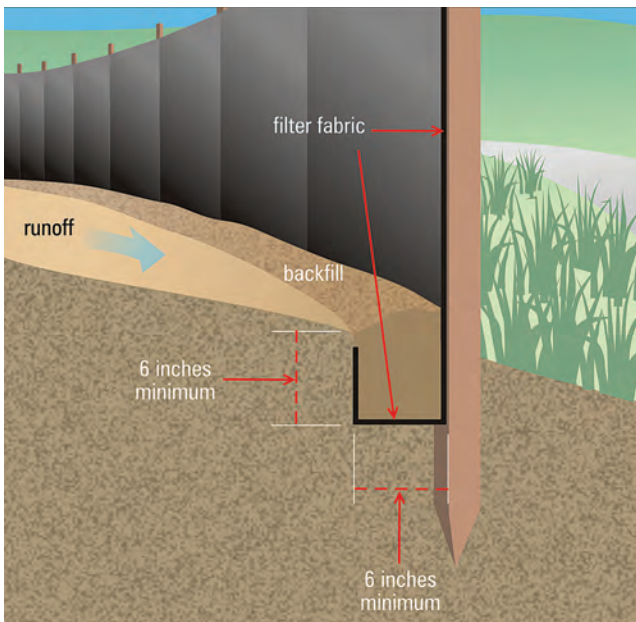

Remember: T posts go on the downhill side. Dig trench first, install fence in downhill side of trench, tuck fabric into trench, then backfill on the uphill side (the side toward the bare soil area).

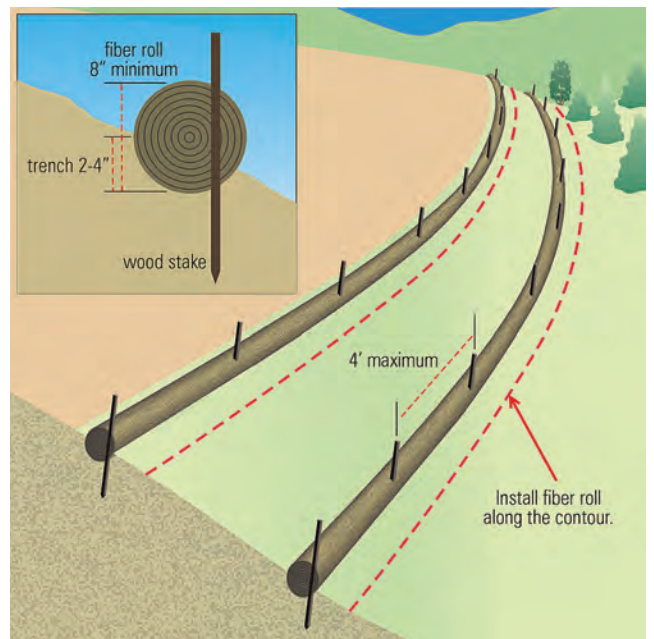

Fiber rolls can be used to break up runoff flows on long slopes. Install on the contour and trench in slightly. Press rolls firmly into trench and stake down securely. Consult manufacturer's instructions for expected lifespan of product, slope limits, etc. As always, seed, mulch and sod long slopes as soon as possible.

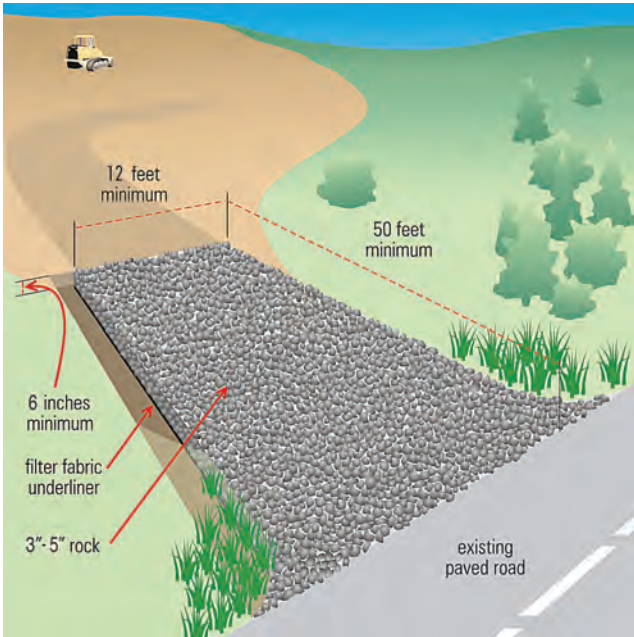

Construction entrance detail. Entrance/exit pad must keep mud from tracking onto paved roads.



Poor construction entrance. Rock pad is poorly constructed; rock is too small. Use filter fabric under rock and larger sized rock, such as 3-5 inches. No mud should be tracked onto paved roads open for traffic.



Rock sizing and placement look OK for a residential site, and very little mud appears on the pavement. The pad is a little thin, however, and it looks like some drivers are not using it—note track marks near curb. Adjacent soil areas need seed and mulch.

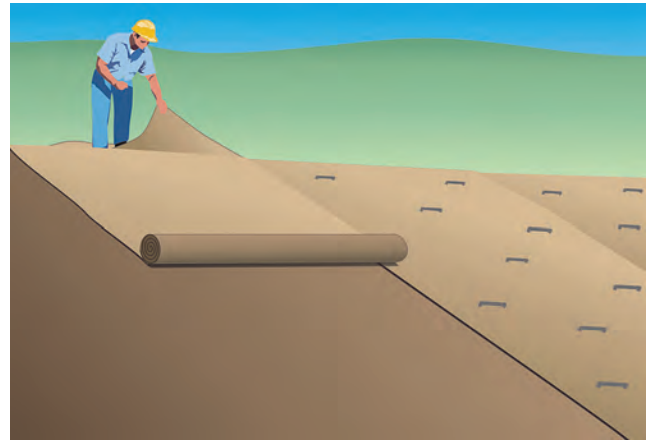

Install blankets and mats vertically on long slopes. Unroll from top of hill, and staple as you unroll it. Do not stretch blankets.



Erosion and sediment loss is virtually eliminated on seeded areas (left side). Rills and small gullies form quickly on unseeded slopes (right side).



Installing sod immediately after grading work is complete can almost completely eliminate erosion and sediment loss.

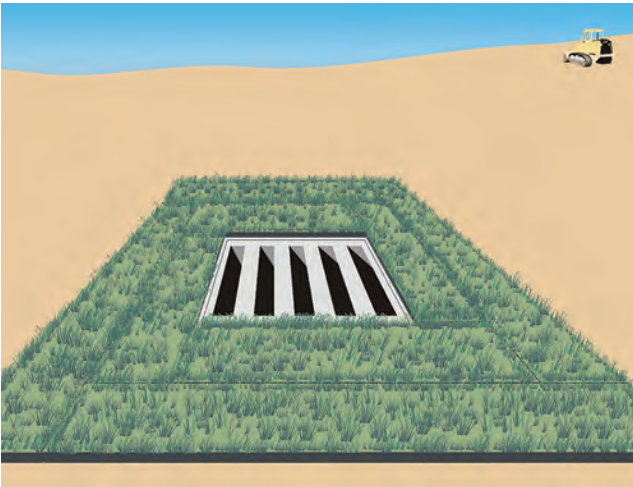

Sod provides immediate protection around storm drain inlets, on slopes, and other areas.



Excellent use of concrete blocks and 2- to 4-inch rock for ponding dam to protect inlet. Note 2 x 4-inch board through blocks for stabilization. Note galvanized fencing and filter fabric between block and rocks.

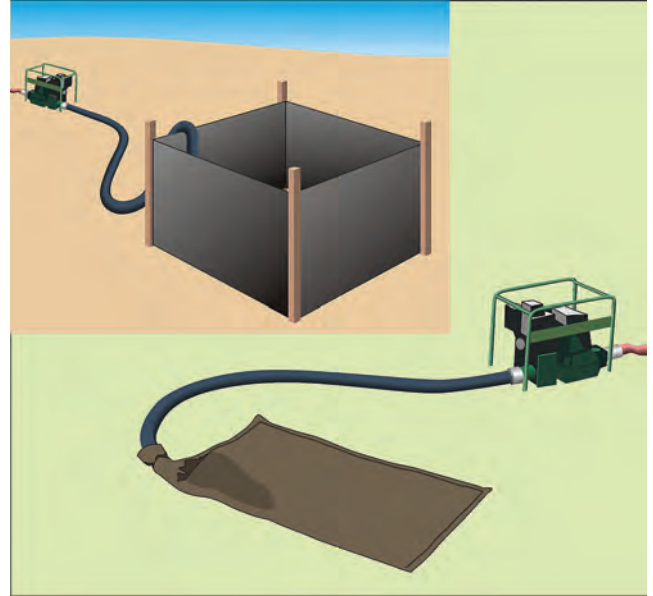

Pump muddy water from dewatering operations away from waterways into a silt fence enclosure or use a bag filter or other device to remove sediment. Allow discharge to soak into the ground if possible. **Do not pump muddy water into curb inlets, storm sewers, creeks, lakes or rivers.**

The following details are provided to help in the installation of common ESCs. For further information on erosion and sediment control practices, contact LCRA (1-800-776-5272, Ext. 3597) to obtain a copy of the Highland Lakes Watershed Ordinance Technical Manual and LCRA's Erosion Prevention and Sediment Control Field Guide.

The worksheet on the last page is to be used as a template in developing an ESC plan for your site. Contact LCRA before you begin land disturbance and the ESC plan is completed. Use the provided ESC diagrams as an example to develop your own site plan.

Send a copy of your ESC site plan to LCRA if your project requires written notification of no permit.

NOTE: Pages 7-14 contain excerpts from LCRA's "Erosion and Sedimentation Control Details." More information can be found at www.lcra.org/water/quality/watershed/index.html.

Soil Protection Blankets and Matting

Soil protection blankets and matting material are used as an aid to control erosion in critical areas such as slopes and channels and to assist in the establishment of protective vegetation. Material selection is based on site conditions (slope or channel condition and soil type). See the [LCRA Water Quality Management Technical Manual](#).

Install blankets per the manufacturer's recommendations. Proper installation of blankets and matting is necessary for these materials to function as intended. Proper anchoring of the material and preparation of the soil are two of the most important aspects of installation.

Notes:

1. Remove clods and rocks more than 1.5 inches in diameter and any foreign material that will prevent contact of the protective mat with the soil surface.
2. Fertilize and seed in accordance with seeding or other type of planting plan.
3. Dig anchor trenches 6 inches wide and 12 inches in depth.
4. Use enough mat to allow a minimum of 2 inch turnover at bottom of trench for stapling, while maintaining the top edge flush with the soil surface.
5. Make sure matting is uniformly in contact with the soil.
6. Secure lap joints and staple (flush with the ground).
7. Inspect blankets and matting weekly and after each rain event (of 0.5 inch or more) to locate and repair any damage. Apply new material if necessary to restore function.
8. Temporary irrigation should be provided. Significant rainfall (on-site rainfall of 0.5 inch or greater per week) may allow watering to be postponed until the next scheduled irrigation.

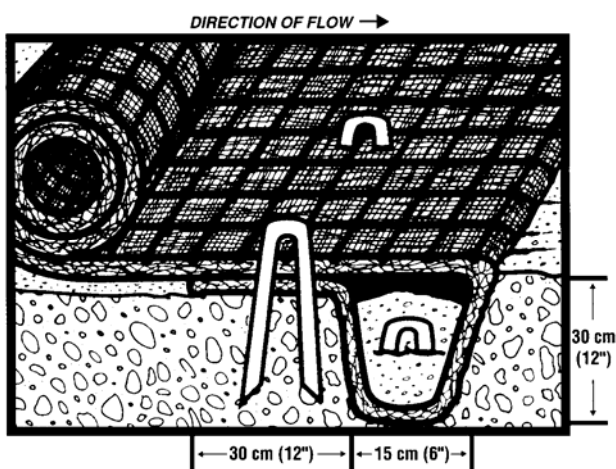

Initial Anchor Trench for Blankets and Mats

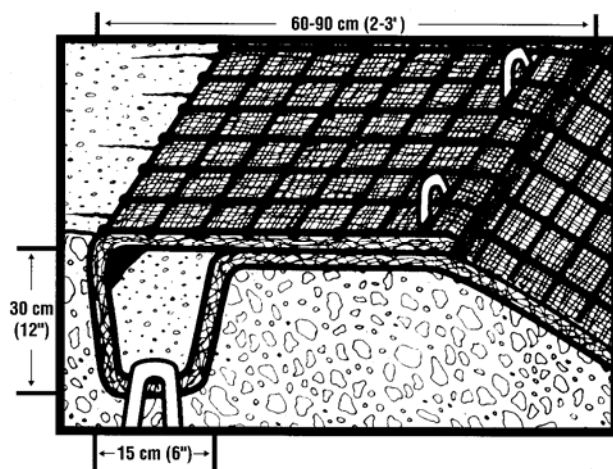

Terminal Anchor Trench for Blankets and Mats

For more information, see the [LCRA Water Quality Management Technical Manual](#)
For questions or information, call LCRA at (800) 776-5272, ext. 2324 or visit www.lcra.org

Temporary Construction Entrance/Exit

The purpose of a temporary construction entrance is to provide a stable entrance/exit condition from the construction site and keep mud and sediment off of roads.

Notes:

1. Use 3 to 5 inch washed stone and place with a minimum thickness of 6 inches.
2. Use geotextile fabric with an approximate weight of 4 oz/yd² as needed to improve stability.
3. The minimum width of the entrance/exit should be 12 feet or the full width of exit roadway, whichever is greater.
4. The construction entrance should be at least 50 feet long.
5. Divert all surface runoff and drainage from the stone pad to a sediment trap or basin if necessary.
6. Inspect entrance/exit and after each rain event (of 0.5 inch or more). Repair any damage by adding stone and/or cleaning any measures used to trap sediment.
7. Promptly remove all sediment spilled, dropped, washed or tracked onto public rights-of-way. Dispose of sediment in a manner that will not cause additional siltation.
8. When construction is complete, properly dispose of any sediment buildup and restore the prior location of the entrance/exit.

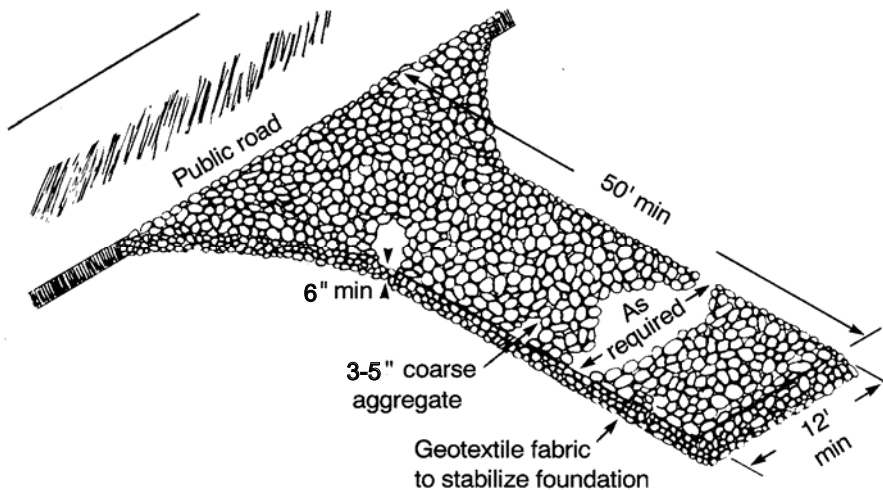

Schematic of Temporary Construction Entrance/Exit

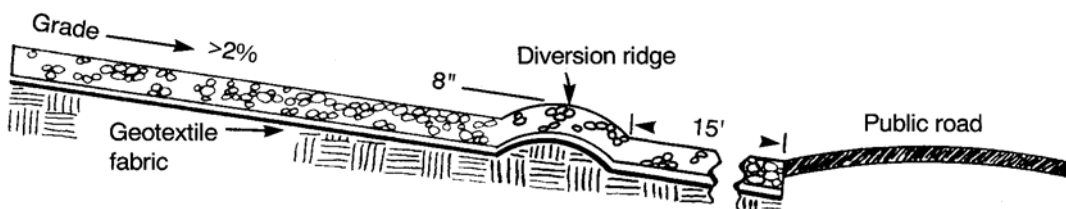

Cross-section of a Construction Entrance/Exit

For more information, see the [LCRA Water Quality Management Technical Manual](#)
 For questions or information, call LCRA at (800) 776-5272, ext. 2324 or visit www.lcra.org

Silt Fence

The purpose of a silt fence is to intercept and detain water-borne sediment from unprotected areas of a limited extent (maximum contributing drainage area of 2 acres).

Notes:

1. Use polypropylene, polyethylene or polyamide woven or nonwoven fabric (36 inches wide, weighing 4 oz/yd) and 2" x 4", 12 gauge minimum woven wire backing.
2. Use steel fence posts, at least 4 feet long, embedded 1-foot deep and spaced not more than 8 feet on center.
3. Toe in the silt fence so that the down-slope face of the trench is flat and perpendicular to the line of flow (6" x 6" trench). Where fence cannot be trenched in (e.g., pavement or rock outcrop), weight fabric flap with 3 inches of pea gravel on uphill side to prevent flow from seeping under fence.
4. Use J-hooks as needed when silt fences cross contour lines to create catchment areas and slow flow velocity. Use J-hooks at downhill fence ends to prevent runoff from escaping around sides. Refer to the J-hook placement detail found below.
5. Inspect silt fences weekly and after each rain event (of 0.5 inch or more) to locate and repair any damage. Replace any torn fabric and repair any sections crushed or collapsed in the course of construction activity.
6. Remove sediment when buildup reaches 6 inches. Dispose of sediment in a manner that will not cause additional siltation.
7. When construction is complete, properly dispose of any sediment buildup and restore the prior location of the silt fence. The fence materials should be disposed of in an approved landfill or reused if in serviceable condition.

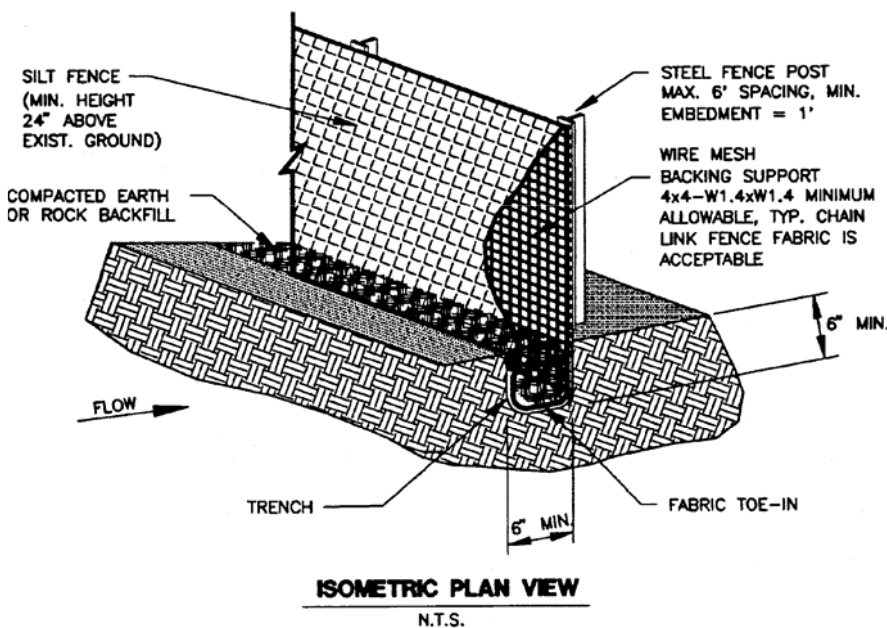

Schematic of a Silt Fence Installation

For more information, see the [LCRA Water Quality Management Technical Manual](#)

For questions or information, call LCRA at (800) 776-5272, ext. 2324 or visit www.lcra.org

Recommended Silt Fence Spacing on Sloping Sites

Slope angle	Soil Type		
	Silty	Clays	Sandy
Very steep (1:1)	50 ft.	75 ft.	100 ft.
Steep (2:1)	75 ft.	100 ft.	125 ft.
Moderate (4:1)	100 ft.	125 ft.	150 ft.
Slight (10:1)	125 ft.	150 ft.	200 ft.

PLAN VIEW

I. SPACING REQUIREMENTS

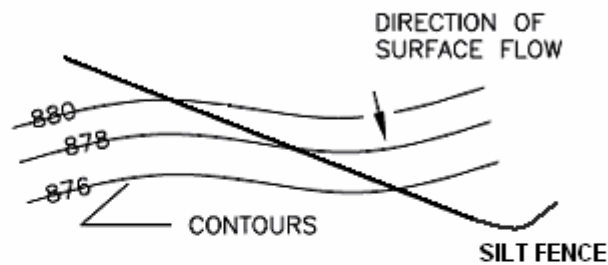
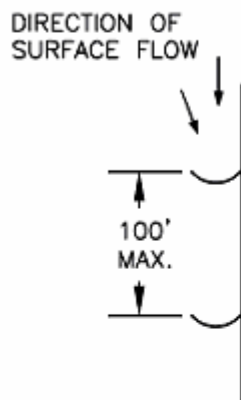

II. SIZING REQUIREMENTS:

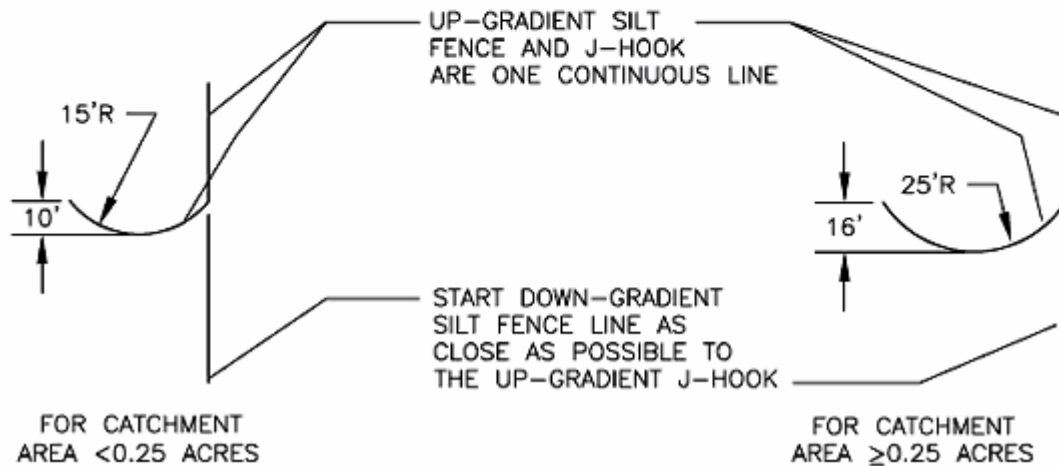

J-hook Placement Details

For more information, see the [LCRA Water Quality Management Technical Manual](#)
 For questions or information, call LCRA at (800) 776-5272, ext. 2324 or visit www.lcra.org

Drop Inlet Protection

In developments for which drainage is to be conveyed by underground storm sewers (i.e., streets with curbs and gutters), all inlets that may receive storm runoff from disturbed areas should be protected. Care should be taken when choosing a specific type of inlet protection, so that excessive ponding in an area of high construction activity does not become so inconvenient that it is removed or bypassed. In such situations, a structure with an adequate overflow mechanism should be utilized.

It should also be noted that inlet protection devices are designed to be installed on construction sites and caution should be used when installed on streets and roads open to the public. When used on public streets these devices will cause ponding of runoff, which can cause flooding and can present a traffic hazard.

Notes:

1. Use a nonwoven filter fence with a minimum weight of 4.0 oz/yd².
2. Use 2" x 4" pressure treated wood stakes or galvanized steel, tubular in cross-section or standard fence "T" posts.
3. Wire mesh should be standard hardware cloth or comparable wire mesh with an opening size not to exceed 1/2 inch.
4. If the drop inlet is above the finished grade, the grate may be completely covered with filter fabric. The fabric should be securely attached to the entire perimeter of the inlet using 1"x 2" wood strips and appropriate fasteners.
5. Inspect frequently and replace the filter cloth and other materials when clogged with sediment. Dispose of sediment in a manner that will not cause additional siltation.
6. When construction is complete, properly dispose of any sediment buildup. The filter fabric materials should be disposed of in an approved landfill. Serviceable components may be salvaged for reuse.

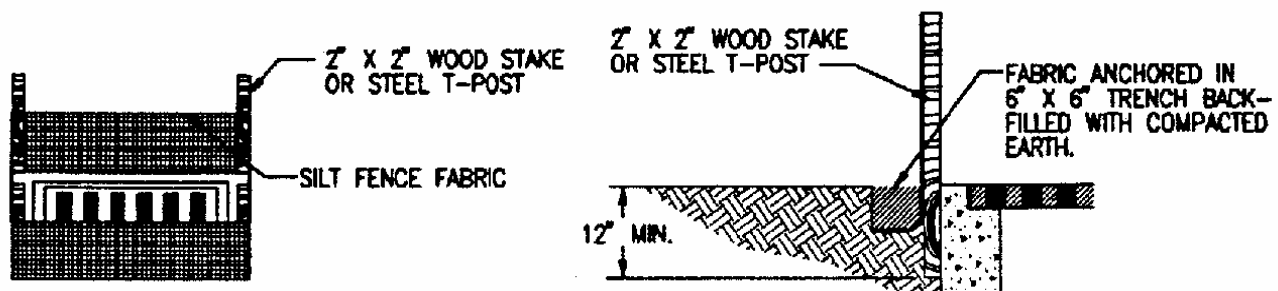

Silt Fence Drop Inlet Protection

Curb Inlet Protection

In developments for which drainage is to be conveyed by underground storm sewers (i.e., streets with curbs and gutters), all inlets that may receive storm runoff from disturbed areas should be protected. Care should be taken when choosing a specific type of inlet protection, so that excessive ponding in an area of high construction activity does not become so inconvenient that it is removed or bypassed. In such situations, a structure with an adequate overflow mechanism should be utilized.

It should also be noted that inlet protection devices are designed to be installed on construction sites and caution should be used when installed on streets and roads open to the public. When used on public streets these devices will cause ponding of runoff, which can cause flooding and can present a traffic hazard.

Notes:

1. Attach a continuous piece of wire mesh (30-inch minimum width x inlet throat length plus 4 feet) to the 2-inch x 4-inch wooden weir (with a total length of throat length plus 2 feet). Wood should be "construction grade" lumber.
2. Place a piece of nonwoven filter fence with a minimum weight of 4.0 oz/yd² of the same dimensions as the wire mesh over the wire mesh and securely attach to the 2-inch x 4-inch weir.
3. Securely nail the 2-inch x 4-inch weir to the 9-inch long vertical spacers which are to be located between the weir and inlet face at a maximum 6-foot spacing.
4. Place the assembly against the inlet throat and nail 2-foot (minimum) lengths of 2-inch x 4-inch board to the top of the weir at spacer locations. These 2-inch x 4-inch anchors should extend across the inlet tops and be held in place by sandbags or alternate weight.
5. The assembly should be placed so that the end spacers are a minimum 1 foot beyond both ends of the throat opening.
6. Form the wire mesh and filter cloth to the concrete gutter and against the face of curb on both sides of the inlet. Place coarse aggregate or sandbags over the wire mesh and filter fabric in such a manner as to prevent water from entering the inlet under or around the filter cloth.
7. The sand bag material should be polypropylene, polyethylene, polyamide or cotton burlap woven fabric, minimum unit weight 4 oz/yd², length of 24 to 30 inches, width of 16 to 18 inches and thickness of 6 to 8 inches. Sandbags should be filled with coarse grade sand, free from deleterious material. The filled bag should have an approximate weight of 40 pounds and stapled or tied with nylon or poly cord.
8. Assure that storm flow does not bypass inlet by installing temporary earth or asphalt dikes directing flow into inlet.
9. Inspect frequently and replace the filter cloth and other materials when clogged with sediment. Dispose of sediment in a manner that will not cause additional siltation. Replace any torn fabric and repair any sections crushed or collapsed in the course of construction activity.
10. When construction is complete, properly dispose of any sediment buildup. The filter fabric materials should be disposed of in an approved landfill. Serviceable components may be salvaged for reuse.

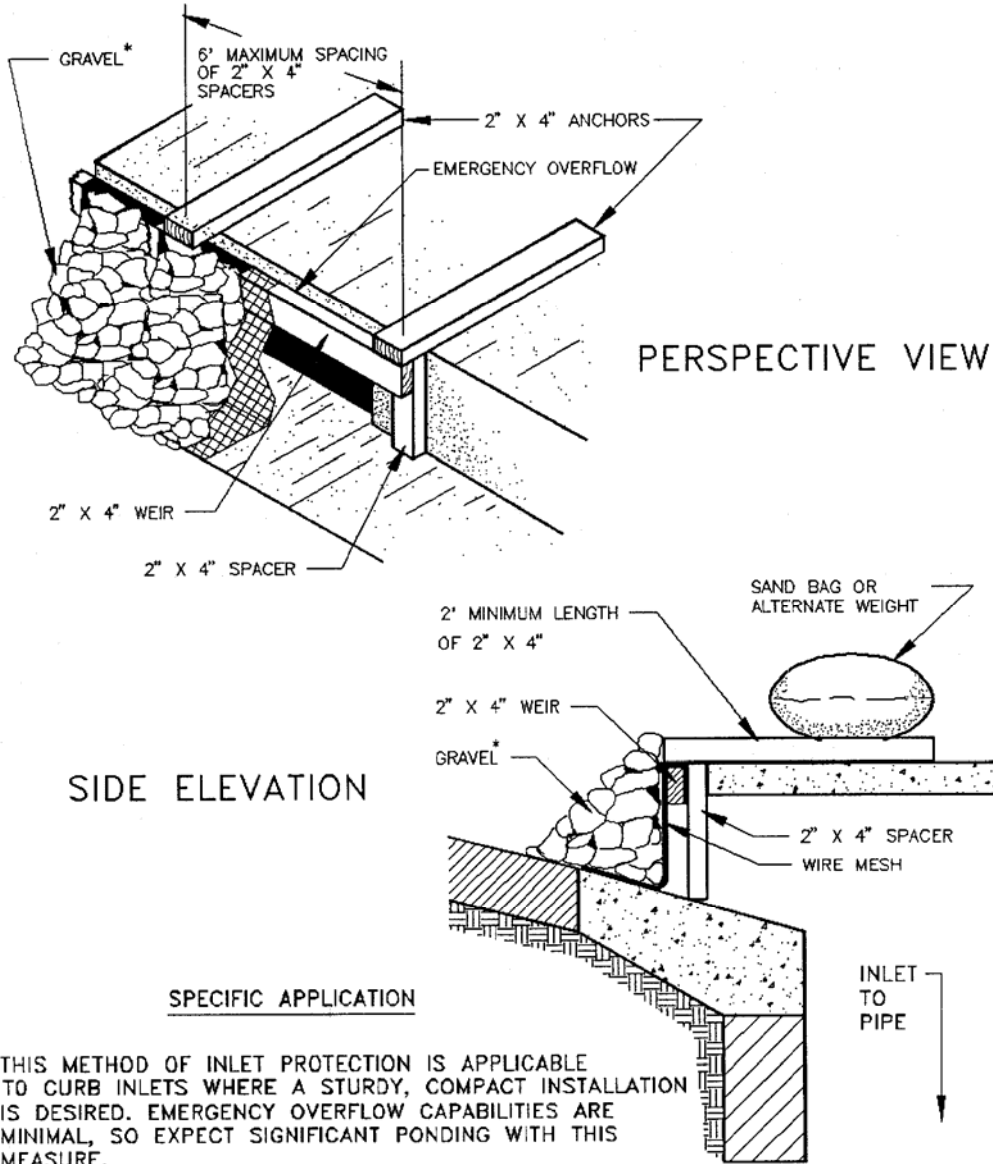

THIS METHOD OF INLET PROTECTION IS APPLICABLE TO CURB INLETS WHERE A STURDY, COMPACT INSTALLATION IS DESIRED. EMERGENCY OVERFLOW CAPABILITIES ARE MINIMAL, SO EXPECT SIGNIFICANT PONDING WITH THIS MEASURE.

*sandbags may be used instead of loose gravel

Wooden Weir Curb Inlet Protection

Concrete Washout Areas

The purpose of concrete washout areas is to prevent or reduce the discharge of pollutants to stormwater from concrete waste by conducting washout offsite, performing onsite washout in a designated area, and training employees and subcontractors.

Notes:

1. Avoid mixing excess amounts of fresh concrete.
2. Perform washout of concrete trucks in designated areas only.
3. Construct washout area using 10 mil plastic lining and anchor the lining with sandbags or rocks.
4. Locate washout area at least 50 feet from sensitive features, storm drains, open ditches, or water bodies. **Do not allow runoff from this area - construct a temporary pit or bermed area large enough to contain both liquid and solid waste.**
5. Wash out wastes into the temporary pit where the concrete can set, be broken up, and then disposed properly, along with the lining.
6. Holes, depressions or other ground disturbance caused by the removal of the temporary concrete washout facilities should be backfilled, repaired, and revegetated or otherwise stabilized.

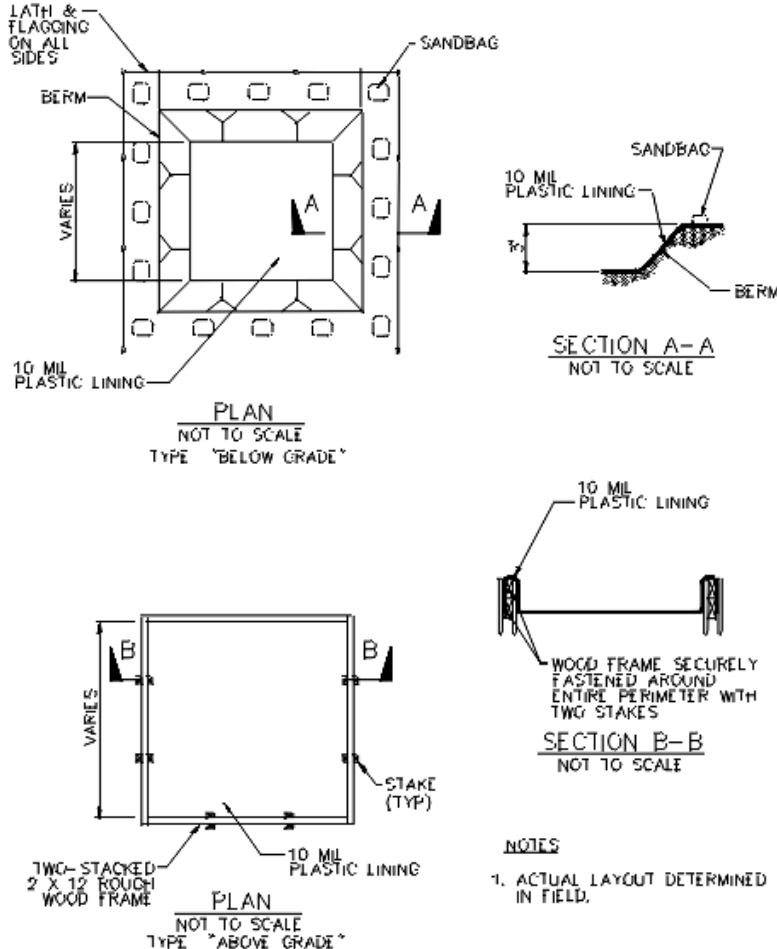

Schematics of Concrete Washout Areas

For more information, see the [LCRA Water Quality Management Technical Manual](#)

For questions or information, call LCRA at (800) 776-5272, ext. 2324 or visit www.lcra.org

ABOUT LCRA

The Lower Colorado River Authority (LCRA) provides public services that help protect people, property and the environment in Texas. LCRA serves customers and communities in the region by managing the lower Colorado River, generating and selling electric power, ensuring a clean, reliable water supply, operating parks, and supporting local economic development initiatives. A nonprofit corporation created by LCRA also provides transmission services to help maintain electric reliability in Texas. LCRA, a nonprofit agency created by the Texas Legislature, cannot levy taxes or receive tax money.



Lower Colorado River Authority
P.O. Box 220
Austin, Texas 78767-0220
1-800-776-5272
www.lcra.org

JANUARY 2010